



# Maintenance Manual for Embroidery Machine

(Color Display Additional Manual)

## HCS-1201-30

Version 1.0

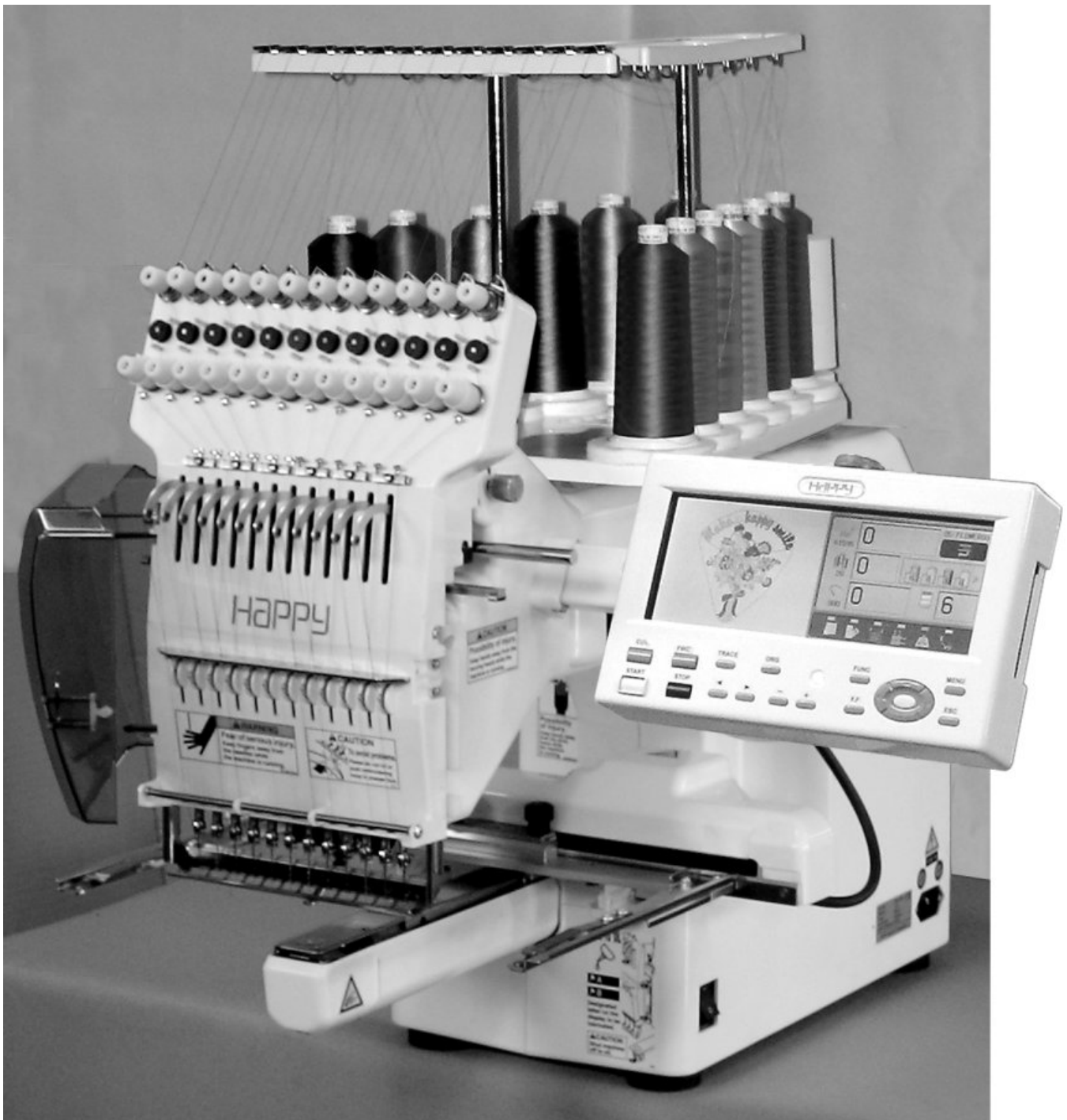

## # For safe adjustment and repair #

In order to conduct adjustment and repair safely and surely,  
please be sure to abide by what is mentioned in this manual to prevent trouble.



1. When you conduct adjustment and repair of this embroidery machine or handle electric related parts, you are required to take technical lesson in advance.
2. When you conduct adjustment and repair using this manual, please be sure to use together with instruction with it in hand.

# Please conduct in accordance with work process in this manual.

# In case there are no specific instructions or explanations in work process.  
please be sure to unplug cord from receptacle.

# When you exchange parts, please be sure to use genuine parts designated by us.

# Please never remodel the embroidery machine.

When you handle circuit boards:

# In order to prevent troubles from static electricity, please remove earth from human body.

# Please don't touch metal part of circuit board with bare hand as it will short-circuit  
and threaten to break circuit boards.

# When you removed circuits boards from the machine or you store or transport them,  
please wrap them in static electricity preventive bag and avoid to give shock.

# Index

	page
cover.....	1
For safe adjustment and repair .....	2
Index.....	3
1 Parts Replacement in control panel and setting .....	4
1-1 Open and remove front panel from control box	
1-1-1 Open the front panel on the control box .....	5
1-1-2 Remove ATA LCD board .....	6
1-2 Dip switch setting for ATA LCD board .....	7
2 Initialization of system .....	8
2-1 Notice for update and Initialize machine systems .....	9
2-2 Operation order for update and Initialize machine systems:.....	10
2-3 Detail operation order for update machine systems	
2-3-1 How to Update Program for Control of ATA LCD Board:.....	11
2-3-2 How to Change Language Setting. ....	12
2-3-3 How to Update CPU Board Program (from EP-ROM) .....	13
2-3-4 How to Update CPU Board Program (from CF card) .....	14
2-3-5 How to Update Internal Monogramming Data .....	15
2-4 Initialization of memory	
2-4-1 Initialization ATA LCD board memory .....	16
2-4-2 Initialization CPU board memory .....	16
2-5 Setting of Revolution .....	17
2-6 Setting to detect needle position (for 12 needles). .....	18.19
3 Maintenance mode.....	20
3-1 How to enter maintenance mode .....	21
3-2 Machine——Machine movement .....	22
3-3 Memory——Memory (Machine and Design) check and all erase.....	23
3-4 Record——Operation data display	
3-4-1 Thread-Pattern-Number of thread brake times in relation to pattern data .....	24
3-4-2 Thread-Needle-Accumulated total of thread break of a needle .....	25
3-4-3 Error——Error occurred and the accrual date .....	26
3-5 Setup——Machine setting. ....	27
4 Electric system diagram(Color Display) .....	28
4-1 Electrical connection diagram:.....	29
4-2 List of electrical connection diagrams .....	30

# 1 Parts Replacement in control panel and setting

1-1 Open and remove front panel from control box

1-1-1 Open the front panel on the control box

1-1-2 Remove ATA LCD board

1-2 Dip switch setting for ATA LCD board

# Open and remove front panel from control box

1-1

## Open the front panel on the control box

1-1-1

<Check> Please check down machine power completely.

1. Remove four setscrews behind of control panel

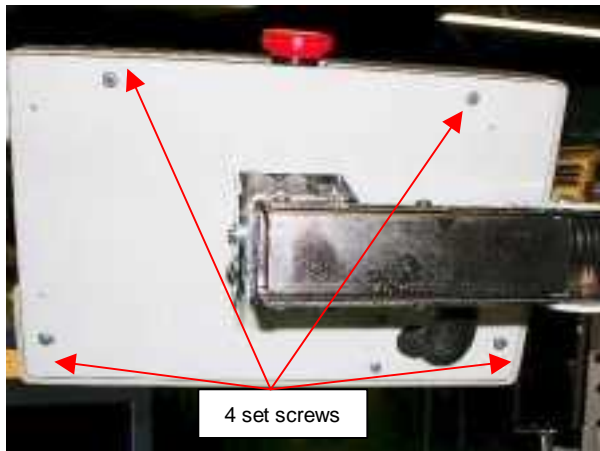

2. Open control panel like following picture.

(Open the cover from right side)

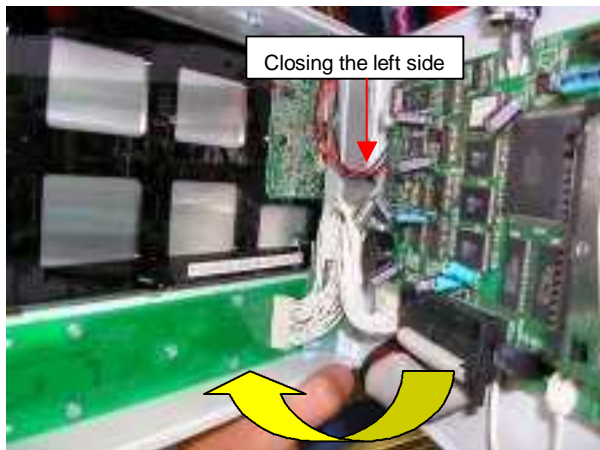

<Note>

Please do not wide open on the left side.

(Possible, make damage to wiring cable and electric board)

Please do not turn on power when inverter cover (refer to the bellow), otherwise the machine might be damaged.

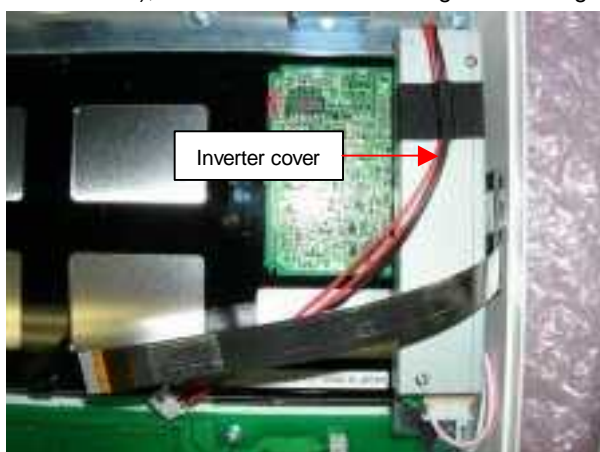

3. Disconnect Inverter power cable.

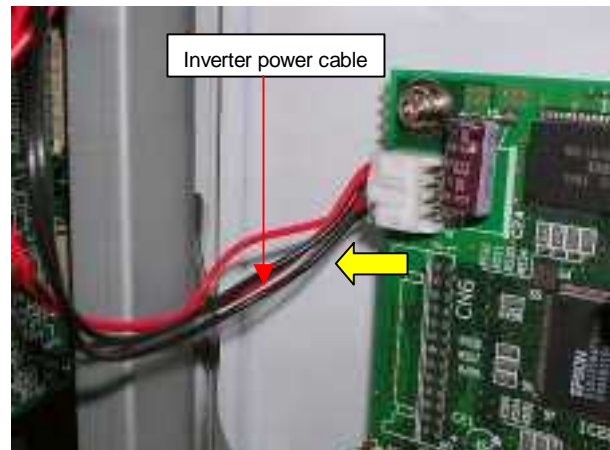

4. Disconnect for LCD-SW cable

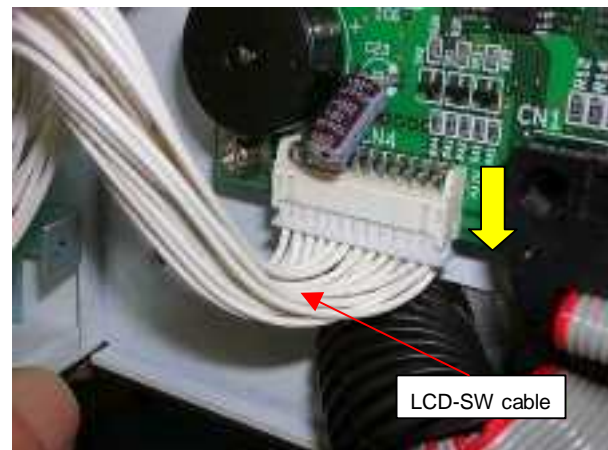

5. Disconnect LCD-S cable.

1. Pull stopper on CN7 (ATA LCD Board)

2. Pull out the LCD-S cable.

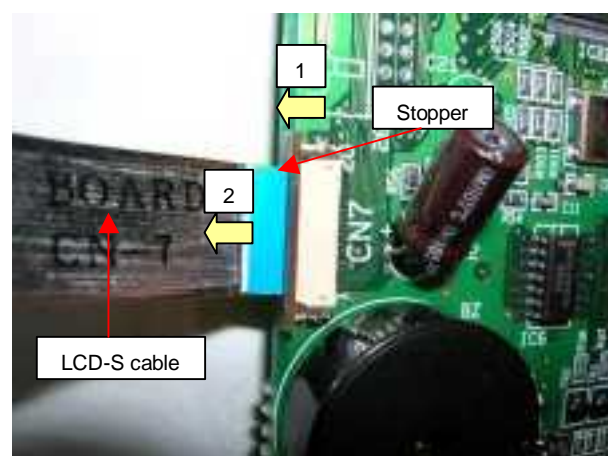

Finish of procedures

For assemble and close this panel: Please opposite steps of this procedure.

# Open and remove front panel from control box

## Remove ATA LCD board

1-1

1-1-2

1. Disconnect emergency SW cable

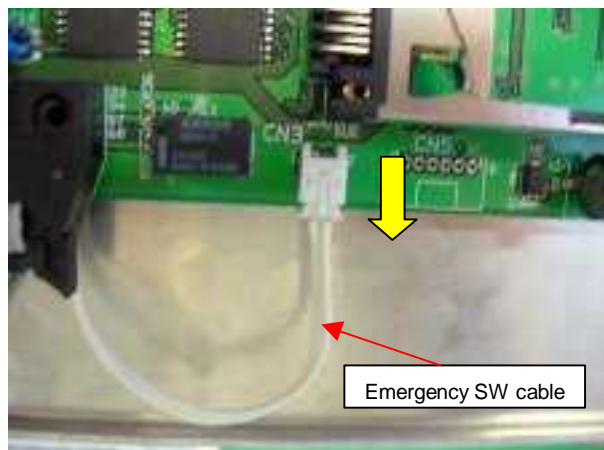

2. Disconnect DISP cable. (Please off stopper first)

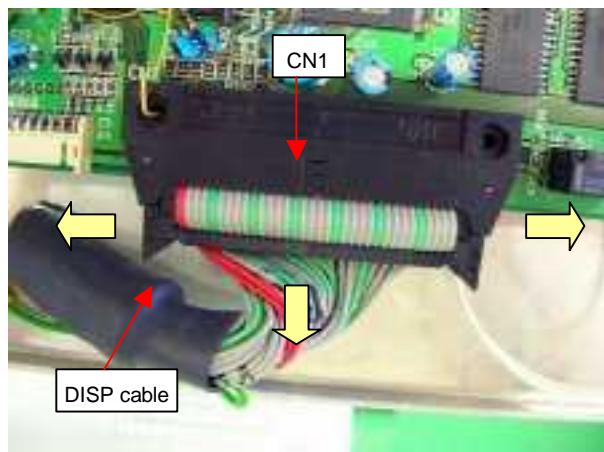

3. Remove ATA LCD board

Remove four setscrews

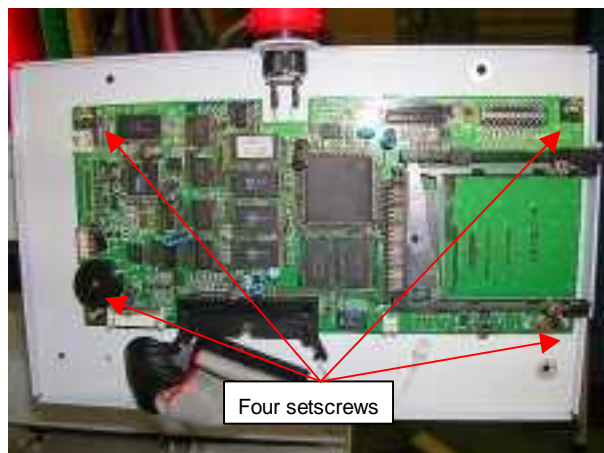

Finish of procedures

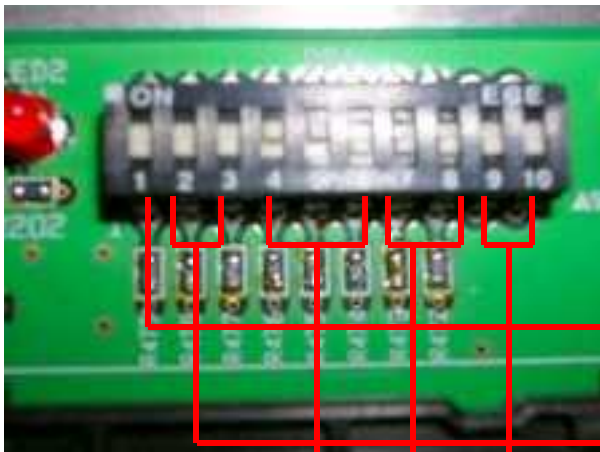

1	-----ON	Initialize back up data	<input type="checkbox"/>	
		Non Initialize(Regular)	<input checked="" type="checkbox"/>	
2	-----OFF	Regular	<input checked="" type="checkbox"/>	
3	-----OFF	Regular	<input checked="" type="checkbox"/>	
4	-----ON	Regular	<input type="checkbox"/>	
5	-----ON			Color LCD Size
6	-----OFF			
7	-----OFF	Regular	<input type="checkbox"/>	
8	-----OFF			External
9	-----OFF	Regular	<input checked="" type="checkbox"/>	
10	-----OFF	Regular	<input checked="" type="checkbox"/>	

Detail of External switch (Normally, dose not use at maintenance)		
7	8	
ON	ON	Forbid
ON	OFF	Erase of language data.
OFF	ON	Forbid
OFF	OFF	Normal machine work(Regular)

## 2 Initialization of system

- 2-1 Notice for update and Initialize machine systems
- 2-2 Operation order for update and Initialize machine systems
- 2-3 Detail operation order for update machine systems
  - 2-3-1 How to Update Program for Control of ATA LCD Board
  - 2-3-2 How to Change Language Setting
  - 2-3-3 How to Update CPU Board Program (from EP-ROM)
  - 2-3-4 How to Update CPU Board Program (from CF card)
  - 2-3-5 How to Update Internal Monogramming Data
- 2-4 Initialization of memory
  - 2-4-1 Initialization ATA LCD board memory
  - 2-4-2 Initialization CPU board memory
- 2-5 Setting of Revolution
- 2-6 Setting to detect needle position (for 12 needles)



\* Please install program when update (Machine system program, Internal Monogram data) and Replace circuit board (CPU board, ATA LCD board) and indication language.

\* Contents of system program for HCD are as follows:

## CPU Board

OS. : HCS/H \*\*\*\* (program for control of CPU board )  
Letter : LTR\*\*\* (Internal Monogramming data)

## LCD Board

Control. : LCDH\*\*\*\* (program for control of LCD board )  
Language. : H\_ENG\*\*\* (English)  
          : H\_JPN\*\*\* (Japanese)

\* System program above will be shown as below on PC screen

Program for control of CPU board : HCS/H \*\*\*\*----->.CHCS\*\*\*.bin  
Internal Monogramming data : LTR\*\*\*----->.LTR\*\*\*.bin  
Program for control of LCD board : LCDHA\*\*\*-----> LCDHA\*\*\*.upi + LCDHA\*\*\*.bin : 2 files required  
Language (English and others) : H\_ENG\*\*\*-----> H\_ENG\*\*\*.upi + H\_ENG\*\*\*.bin : 2 files required

### <NOTE>

Please do not write system program in folder in CF card when you upgrade machine by writing system program in CF card by PC as machine becomes unable to recognize version up program (please write system program on route of subject media).

\* In case, upgrade plural programs same time, please keep following priority install order.

- 1:LCDH\*\*\*\*( program for control of LCD board )
- 2:H\_ENG\*\*\* or H\_JPN\*\*\* (language)
- 3:HCS/H \*\*\*\*( program for control of CPU board )
- 4:LTR\*\*\*( Internal Monogramming data)

### <NOTE>

\* After replace board and upgrade program, please operate following items.

1. After upgrade LCD board program (Control and Language), please operate chapter [2-4-1 Initialization ATA LCD board memory LCD] for clear a memory.
2. After update CPU board program (OS and Letter), please reference following chapters for set Memory clear, set machine speed, needle position, system initialize and calendar set.
  - 1: [2-4-2 Initialization CPU board memory ]
  - 2: [2-5 Setting of Revolution]
  - 3: [2-6 Setting to detect needle position (for 12 needles)]
  - 4: [3-3 memory (Machine and Design) check and all erase]
  - 5: In an Instruction book [25-1.2 Initialize machine] and [3-7 Calendar setting]
3. You can install and update all program from CF card.

But, in case of you have problem of electricity whole program install, possible loose CPU operation program completely. In this time you need install CPU operation program from EP-ROM tip only.

\* Work sequence of Updating Program are described below.

If you need more detail information fro each sequence, please reference each manual

- |  |   |   |
|--|---|---|
| <p>1. Insert CF card saved update program to slot of control panel.<br/>Press and keep [MENU] button and turn on the machine</p> <hr/> <p>2. Go to maintenance mode and practice install.</p> <hr/> <p>3. Update [CPU board program] from EP-ROM tip.<br/>(In case, Machine program brake completely, you can re-install CPU board program only from EP-ROM tip)<br/>Turn off machine and connect EP-ROM saved machine program tip to socket on CPU board.<br/>Flip dipswitch [DSW2 to OFF] and [DSW4 to ON], then turn on machine.<br/>Start copy of CPU board program automatically.<br/>After a copy, Please turn off machine power and flip back dipswitch [DSW2 to ON] and [DSW4 to OFF].</p> <hr/> | } | <p>2-3<br/>UPDATE PROGRAM</p>                         |
| <p>4. [Update LCD board control program]<br/>Flip dipswitch [DSW1 to ON] on ATA LCD board. And turn on machine.<br/>Starts initialize</p> <hr/> <p>5. [Update LCD board control program]<br/>Turn off machine power And Flip back dipswitch {DSW1 to OFF}.</p> <hr/> <p>6. Flip dipswitch [DSW1 to OFF] on CPU board. And turn on machine.<br/>Starts initialize memory.</p> <hr/> <p>7. Turn off machine and flip back dipswitch [DSW1 to ON] on CPU board.<br/>Press and keep [MENU] button and turn on machine power.</p> <hr/>   | } | <p>2-4<br/>Initialize memory</p>                      |
| <p>8. Memory checks at maintenance mode.</p> <hr/> <p>9. Re-turn on the machine<br/>Come up [E-120] on display, and press [SET] button for turn off machine power.</p> <hr/> <p>10. Press and keep [MENU] button and turn on machine power.</p> <hr/>  | } | <p>3-3<br/>Check and all clear a memory</p>           |
| <p>11. Needle setting at maintenance mode.<br/>("D" for 1<sup>st</sup> needle ,"E" for 12<sup>th</sup> needle ,"F" for check)</p> <hr/>  | } | <p>2-6<br/>Needle position setting</p>                |
| <p>12. Exit maintenance mode.( Press [ESC] button for back to drive mode)<br/>Check moving head working correctly.</p> <hr/>   |   |   |
| <p>13. Initialize machine system</p> <hr/> <p>14. Machine speed teaching</p> <hr/>   | } | <p>Instruction book<br/>25-1.2 Initialize machine</p> |
| <p>15. Calender setting</p> <hr/> <p>16. end of process</p>  | } | <p>Instruction book<br/>3-7 Calendar setting</p>      |

1. Update of ATA LCD board program

Insert CF card contains data for version up into CF card insertion slot

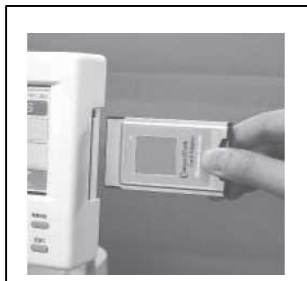

2. Refer to "3-1 How to enter maintenance mode" and enter maintenance mode. Display comes as below.

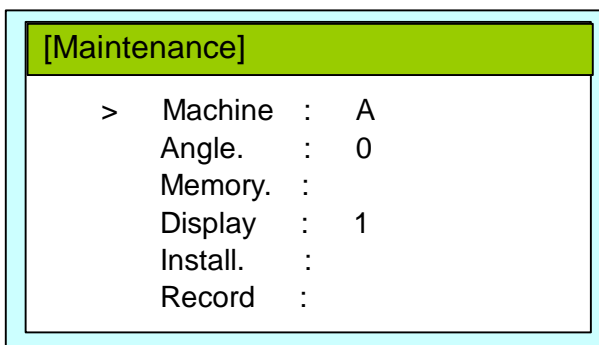

3. Place cursor at [ Install ] by  button and press **SET** button.

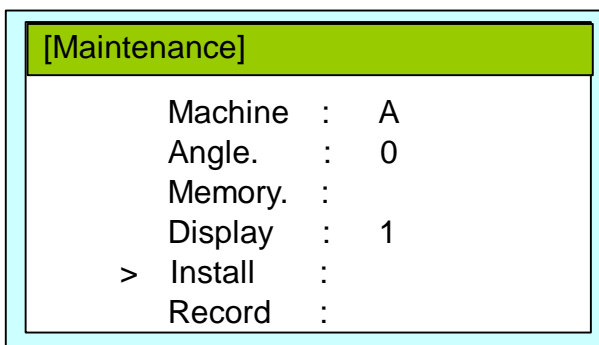

4. Showing menu on right side of screen.

Select [ install ] by  button and press **SET** button.

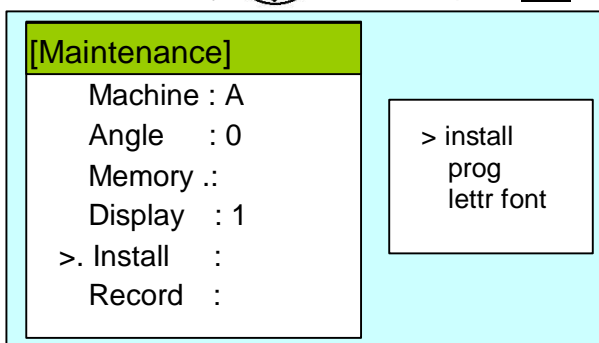

5. Display comes as below after reading data in CF card

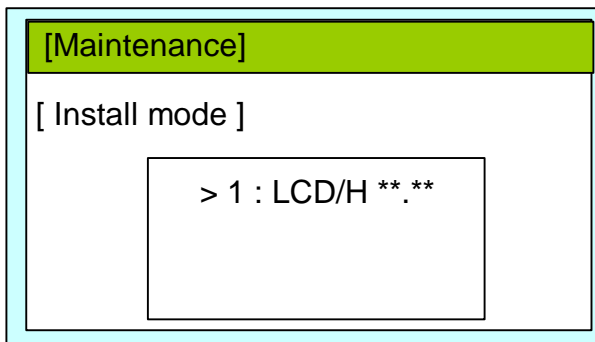

6. Press **SET** button for update of ATA LCD board program

<NOTE>

\* Please do not take out CF card during installation.

\* Will show following message

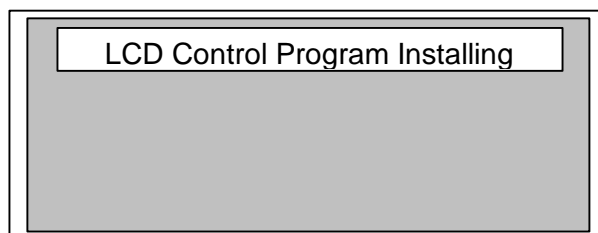

\* For cancel, press **ESC** button and back to last menu

7. Completely, and re-boot machine.

If you have [ Error ] message, please operate from step 1 of this process again.

\* End of process

1. Change language of LCD panel

Insert CF card included language data to card slot of control panel. Refer to “3-1 How to enter maintenance mode” and enter maintenance mode. Display comes as below.

2. Set cursor at [ Install ] by  button and press **SET** button.

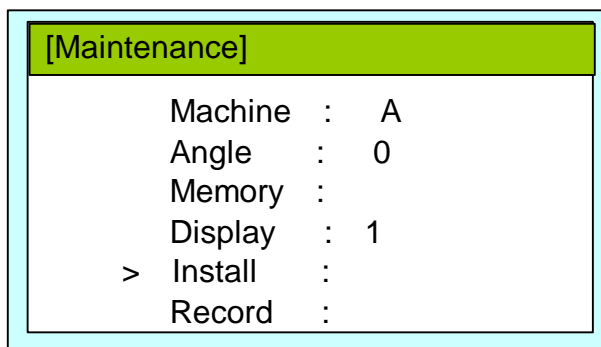

3. Will show the menu on right side.

Set cursor at [ install ] by  button and press **SET** button.

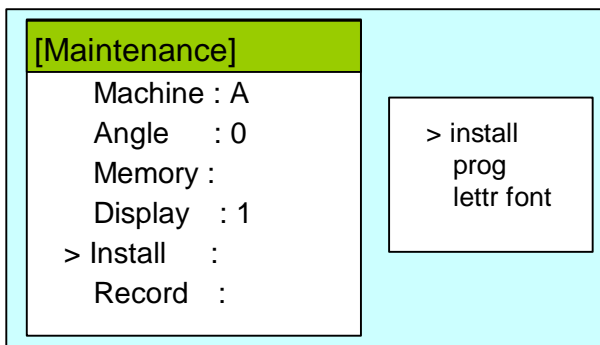

4. Display comes as below after reading data in CF card

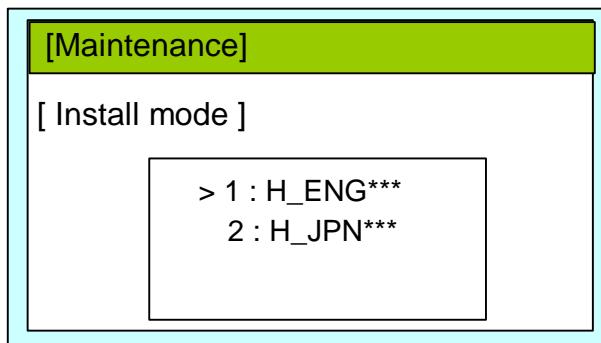

5. Select your language and press **SET** button. Start install automatically.

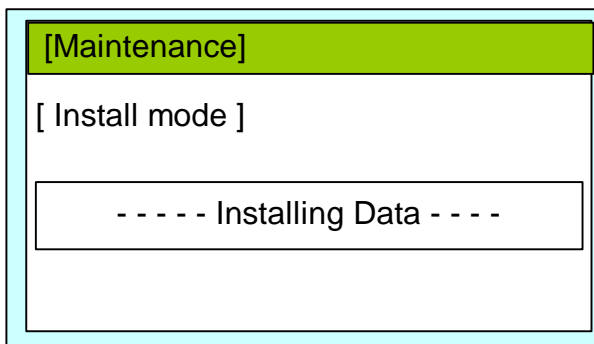

\* File name of language

- English    H\_ENG\*\*\*
- Japanese  H\_JPN\*\*\*
- German     H\_GER\*\*\*
- Danish     H\_DAN\*\*\*

<NOTE>

\* Please do not take out CF card during installation.

For cancel, press **ESC** button and back to last menu.

6. Indicate [ complete ], then return to drive menu automatically.

Please retry when you have display as “ Error ” by mistake of writing.

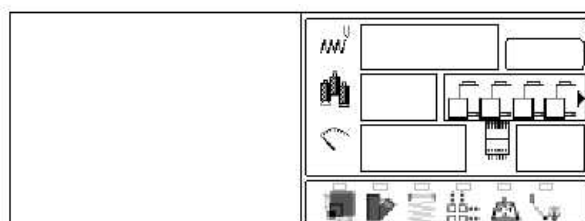
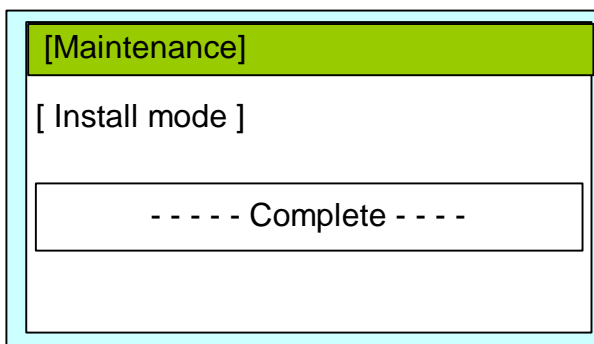

\* end of process

## 1. Update of CPU board program

Insert ROM in socket with power off

Control-program  
[HCS/H \*\*. \*\*]



Dented side on the bottom.

2. Set No.4 of [DS1] to [ON] and No.2 to [OFF] to turn power on.

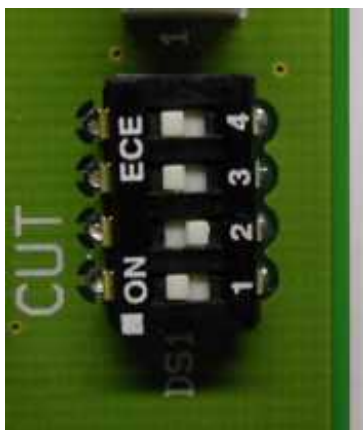

Indicating process

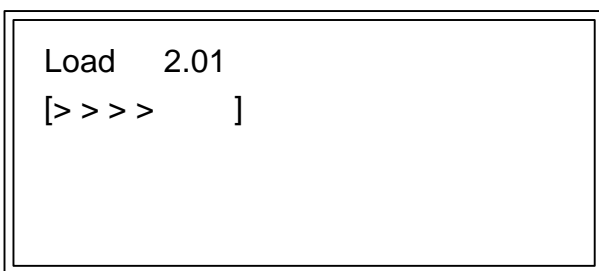

## 3. Display [complete]

When you make wrong writing, message of "error" will be displayed. Please write again



## <Judgment by circuit board itself>

Lighting condition of LED4 on the CPU Board enables you to distinguish the result.

Normal complete : 8times blinking --- lighting

Writing error : 8times blinking --- blinking

Retry if writing error occurs.



4. Turn power off and set No.4 of DS1 to OFF, No.2 to ON.

5. Remove ROM.

\* End of process

1. Update of CPU board program

Insert CF card contains data for version up into CF card insertion slot

2. Refer to "3-1 How to enter maintenance mode" and enter maintenance mode. Display comes as below.

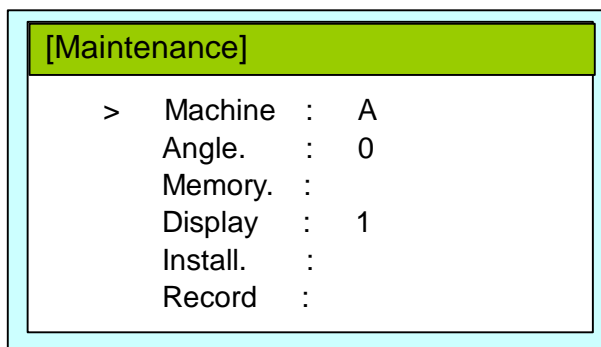

3. Place cursor at [Install] by  button and press **SET** button.

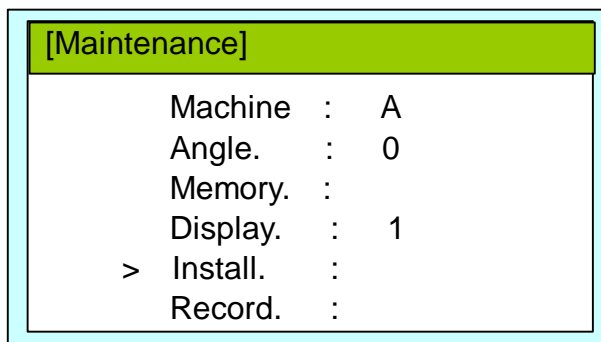

4. Display menu on right side below.

Select [ prog ] by  button and press **SET** button.

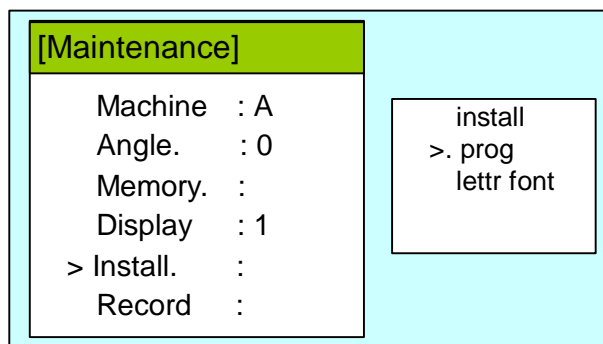

5. Display comes as below after reading data in CF card

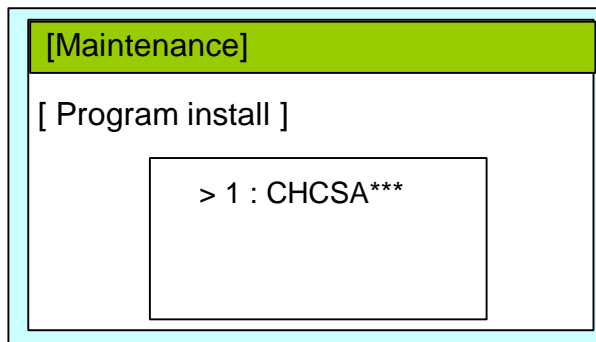

6. Press **SET** for start program update

<NOTE>

\* Please do not take out CF card during installation.

\* For cancel, press **ESC** button and back to last menu.

\* Display comes as below.

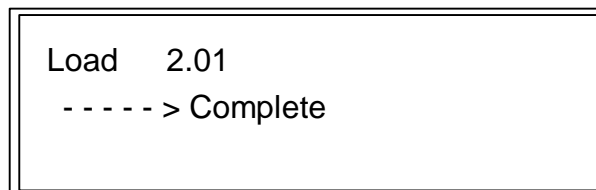

12. When completed, reboot machine automatically

Please retry when you have display as "Error" by mistake of writing.

\* End of process.

1. Update for Internal Monogram data.

Insert CF card saved update data. Refer to “3-1 How to enter maintenance mode” and enter maintenance mode.  
Display comes as below.

2. Place cursor at [ Install ] by  button and press **SET** button.

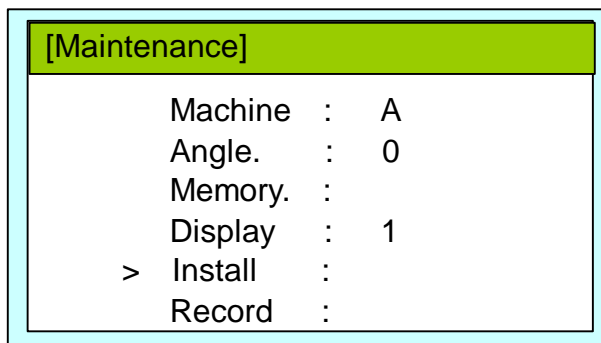

3. Showing menu on right side of screen

Select [ letter font ] by  button and press **SET** button.

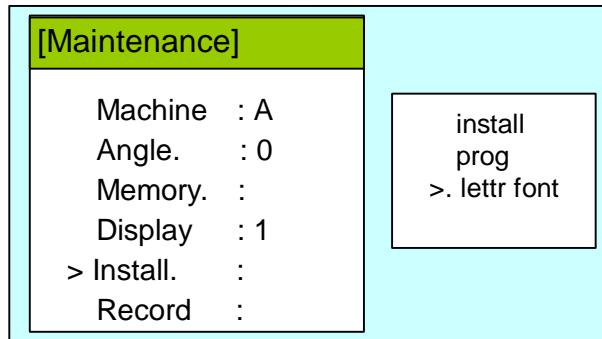

4. Display comes as below after reading data in CF card

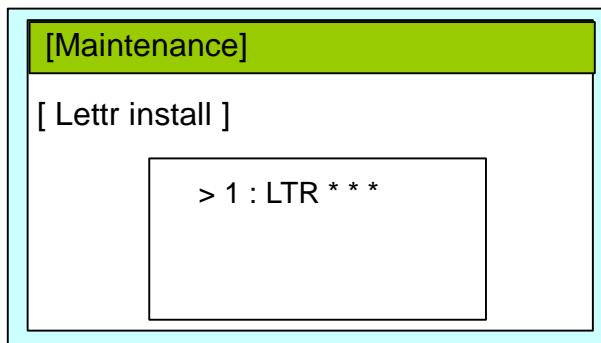

5. Press **SET** button for start update of monogram data.

<NOTE>

Please do not take out CF card during installation

For cancel, press **ESC** button and back to last menu.

6. When completed, comes as below display [ complete ] and reboot machine automatically.

Please retry when you have display as “Error” by mistake of writing.

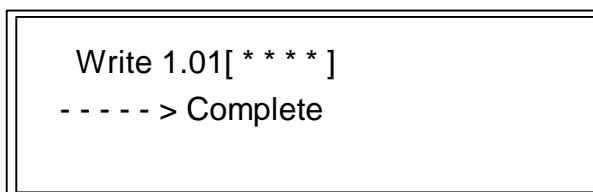

\* End of process

## Initialization of memory

2-4

---

At time of start-up, this is to initialize work memory to specified value. Initialization takes place

Initialize “work memory”. Please practice when you have problem example, strange display, strange machine working. After initialize “working memory”, Please set machine speed and needle position setting.

---

## Initialization ATA LCD board memory

2-4-1

---

1. Please flip dipswitch DS1-1 on ATA LCD board. Then turn on the machine



2. End of initialize. Please turn off machine and flip back dipswitch DS1-1 to [OFF].

---

## Initialization CPU board memory

2-4-2

---

1. Set DS1-1 on CPU board to [OFF] to turn power on.

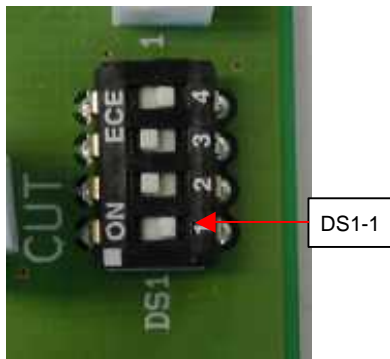

2. You will have no problem in starting and finishing initialization. Please turn power off to set DS1-1 to ON after initialization

3. Please set as refer following process.

1. [2-5 Setting of Revolution]
2. [2-6 Setting to detect needle position (for 12 needles)]
3. Instruction book [25-1.2 Initialize machine] and [3-7 calendar setting]

### <NOTE>

You are unable clear pattern memory area. If you want to clear, Please refer to [3-3 memory (Machine and Design) check and all erase ].



# Setting of Revolution

Setting of revolution of main shaft, which is suitable to the machine is required.

If setting is not done, the revolution may not speed up.

1. Turn on the power. After the program start up, press **MENU** button.

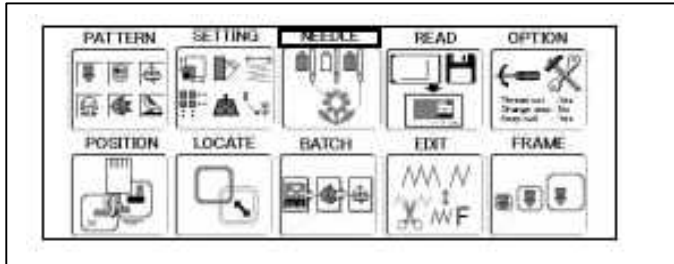

2. Press to select **OTHER** window and press **SET** button.  
Displayed as bellow.

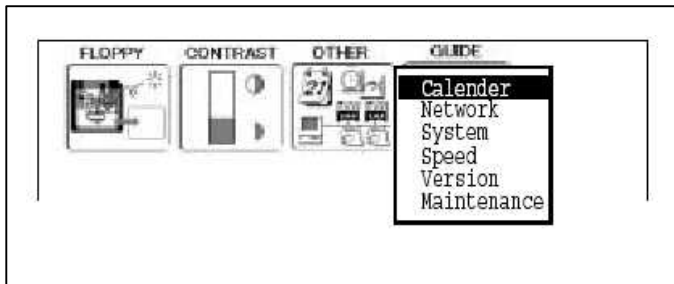

3. Press to select **Speed** and press **SET** button.  
Press to select **[OK]** and press **SET** button.

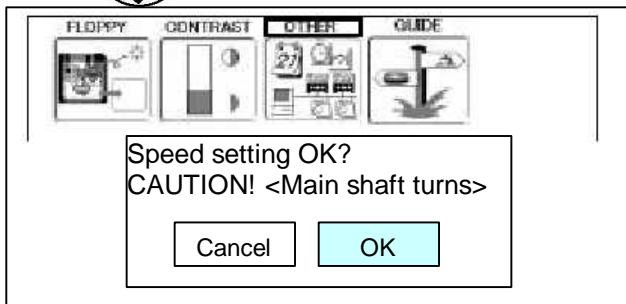

5. Main shaft adjusts its revolution speed automatically.  
Message **complete** will be displayed when setting is finished and it goes back to drive mode.

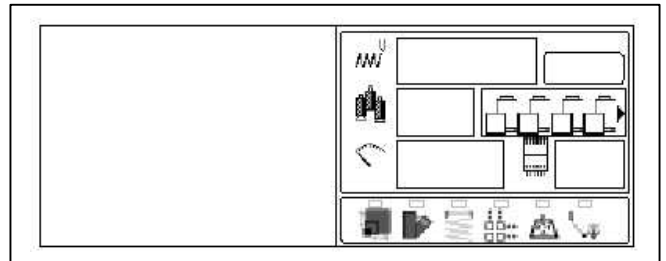
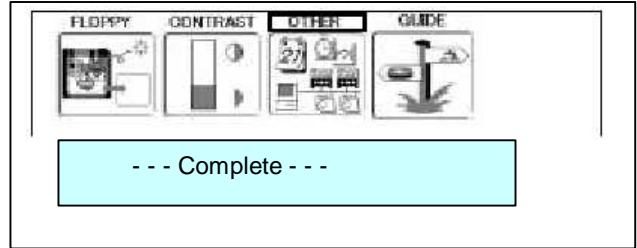

End of process.

# Setting to detect needle position (for 12 needles)

It is necessary to store value of needle selection sensor according to number of needles. If this setting is not made, normal needle selection may not be made.

- 1. Sift moving head to first needle by hand turning knob

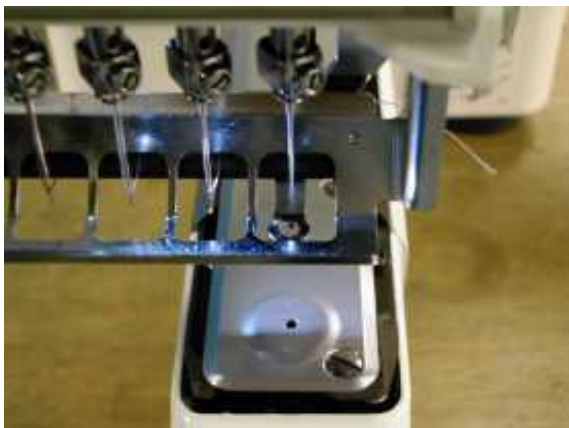

- 2. Refer to "3-1 How to enter maintenance mode" and enter maintenance mode.

- 3. Place cursor at [ machine ] by  button and press **SET** button

[Maintenance]	
> Machine	: A
Angle.	: 0
Memory.	:
Display	: 1
Install.	:
Record	:

- 4. Press  button and select " D " then press **SET** button. Memory first needle position to machine.

[Maintenance]	
> Machine	: # D
Angle.	: 0
Memory.	:
Display	: 1
Install.	:
Record.	:

### <Check>

When you press **SET** button, comes up " # " mark split second for proof memory needle position to machine completely.

- 5. Slide moving head to 12<sup>th</sup> needle by hand.



6 Press  button and select " E " then press **SET** button. Memory 12th needle position to machine.

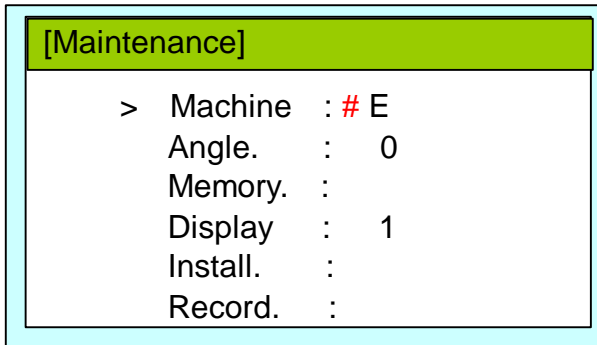

<Check>

When you press **SET** button, comes up " # " mark split second for proof memory needle position to machine completely.

7. Press  button and select " F " then press **SET** button.

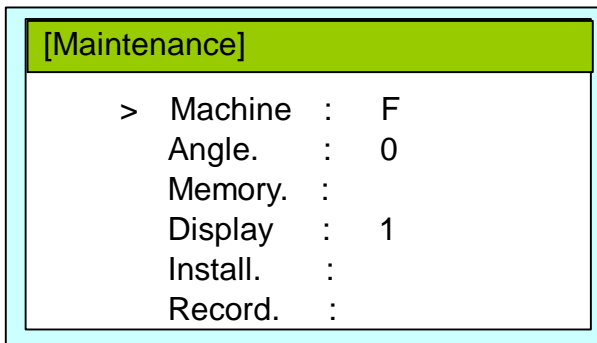

8. Right side of [ : F ] Indicate present needle number on display.

Please slide moving head by hand and confirm 1 to 12 all needle displayed number and present needle number

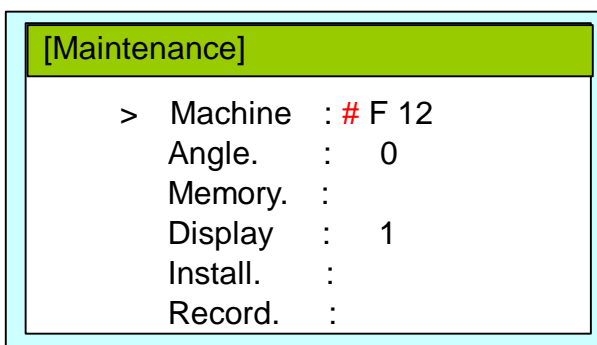

9. Press **SET** button for return to top menu of maintenance mode.

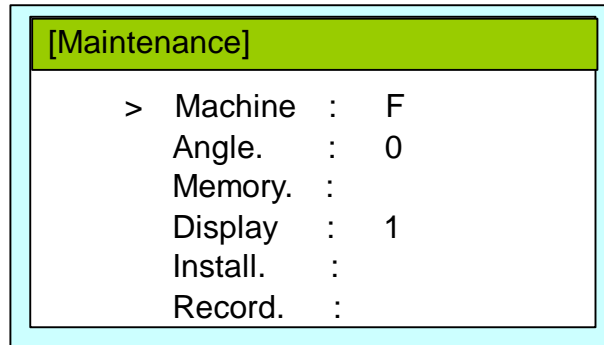

10. Press **ESC** button for back to drive mode.

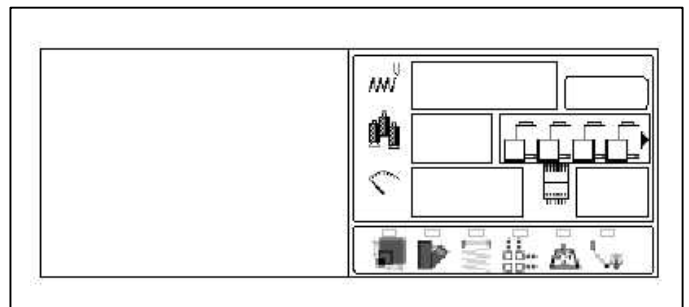

End of process

## 3 Maintenance mode

- 3-1 How to enter Maintenance mode
- 3-2 Machine—Machine movement
- 3-3 Memory—Memory (Machine and Design) check and all erase
- 3-4 Record—Operation data display
  - 3-4-1 Thread-Pattern-Number of thread brake times in relation to pattern data
  - 3-4-2 Thread-Needle-Accumulated total of thread break of a needle
  - 3-4-3 Error—————Error occurred and the accrual date
- 3-5 Setup—Machine setting

We have 7 maintenance modes as mentioned below

- Machine————Motion of machine
- Angle————Display of machine angle (No use for basic maintenance service.)
- Memory————Check memory and clear all memory
- Display————Switch over the display mode of LCD(Normally not used at maintenance)[1 fixation]
- Install————Update of Control program Installation of Displayed language data
- Record————Display of data of machine in operation
- Setup————Setting of machine

## How to enter maintenance mode

3-1

Enable to enter maintenance mode with below procedure, which is not displayed normally.

1. Turn on machine with keep **MENU** button pressed.

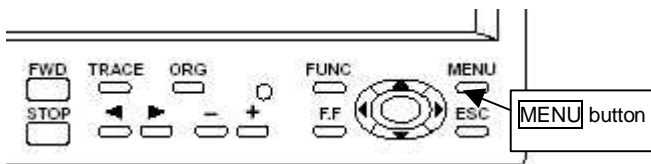

**<NOTE>**

Keep **MENU** button pressing until below display will come.



2. press **SET** button

**<NOTE>**

The frame has a sudden move. Keep hands away from the frame.

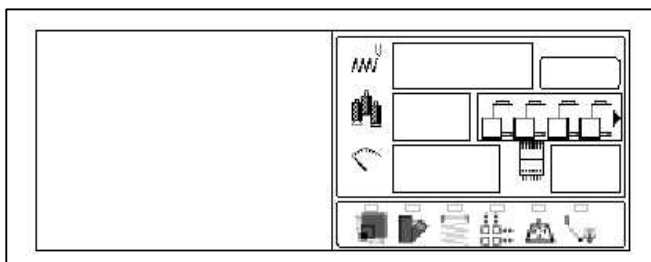

\* The above is displayed

3. Press to select **OTHER** window and press **SET** button.

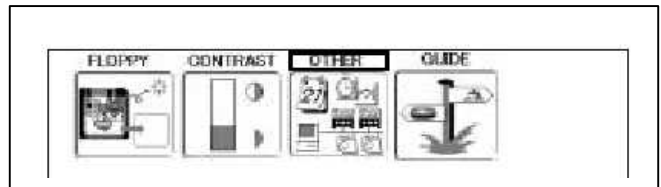

4. Press to select **Maintenance** window and press **SET** button.

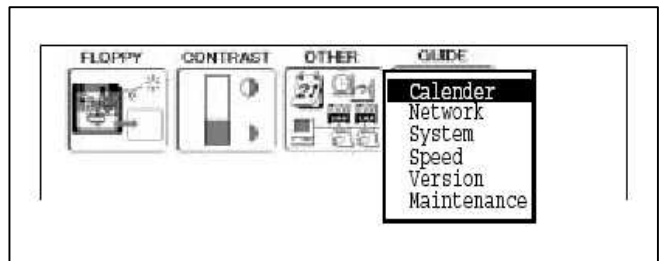

5. Press to Input Code to make it [ 2251 ], then press **SET** button.

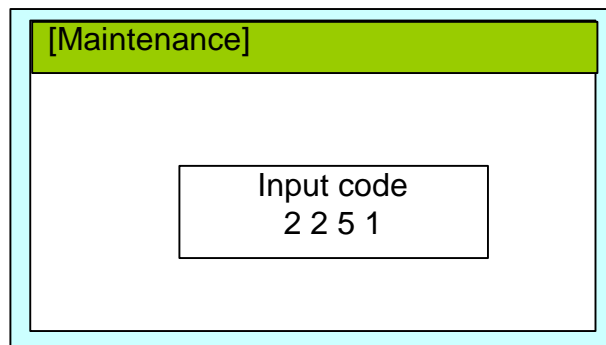

(while you don't turn power off, input code is displayed again)  
By this operation, you can enter maintenance mode.

Automatic operation is conducted as bellow. Actuator like a motor might operate according to the contents. During the operation, it is danger, so keep away your face and hand from it.

### Machine

- A : checking of turning of main shaft
- B : Automatic speed Adjustment of main shaft
- C : Operation of main shaft with low speed
- D : Setting of needle number at right side
- E : Setting of needle number at left side
- F : Checking of needle number
- G : Moving needle selection to right (for 1 needle)
- H : Moving needle selection to left (for 1 needle)
- I : Individual action of thread catch
- J : Individual action of thread cut solenoid
- K : Individual action of jump solenoid
- L : Individual action of brake solenoid
- M : Individual action of keeper solenoid
- N : Individual action of pressure foot up
- P : Individual action of pressure foot down
- Q : } No use
- ↓
- Z : }

1. Refer to “3-1 How to enter maintenance mode” and enter maintenance mode

2. Place cursor at [ machine ] by  button and press **SET** button

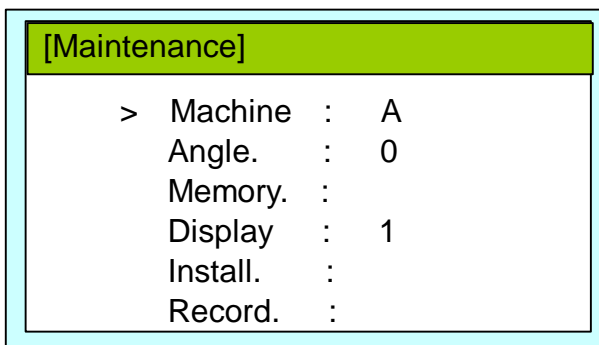

3. Press  to select desired number to be confirmed and press **SET** Button  
[ # ] mark will be displayed left side of desired number to be confirmed and selected item will be executed

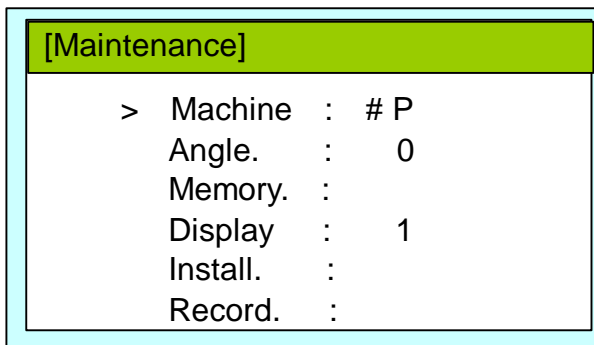

4. By pressing **ESC** button [ # ]mark will be disappear and return to number setting display (Unnecessary to press **ESC** button if the item complete automatically)

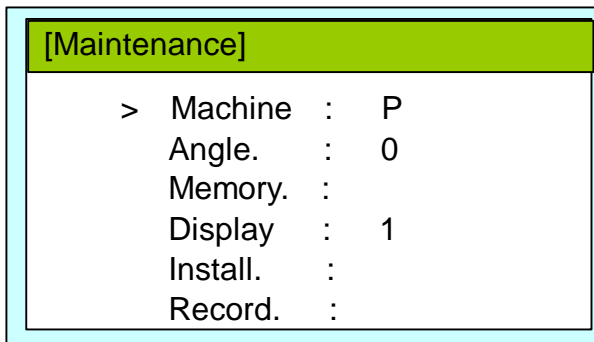

5. Enable to Quit maintenance mode and return to drive mode by pressing **ESC** button

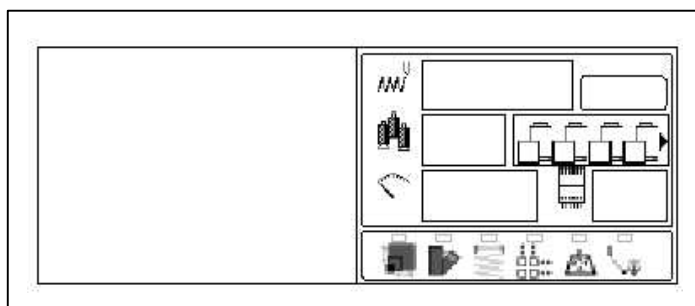

Delete all the design memory with checking movement of design memory area.

After this process, turn off the power. When you restart the machine, [ E-120 ] is displayed. Press **SET** Button, turn off the power and turn on again.

When you face situation that you can't put pattern in or pattern was destroyed, or when you replace CPU circuit board, please conduct this mode.

When something is wrong, malfunction of circuit board is conceivable. Please replace it.

**<Note> All the design memory will be deleted. Before this process, please check them.**

# Clock display will be initializing by all clear. After all clear, make each setting, referring to [2-5 Setting of revolution],[2-6 Setting to detect needle position (12 needle)]and [25-1.2 Initialization of embroidery machine]and [3-7 Date / Time] at supplementary Instruction manual.

1. Refer to “3-1 How to enter maintenance mode” and enter maintenance mode

2. Choose [ Memory ] with  and press **SET** button

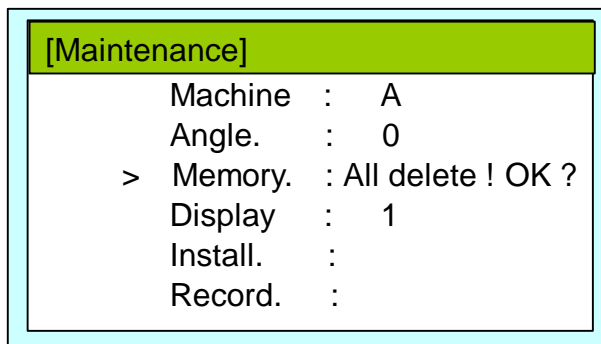

\* Above will be displayed

3. Press **SET** Button to check memory and start all clear

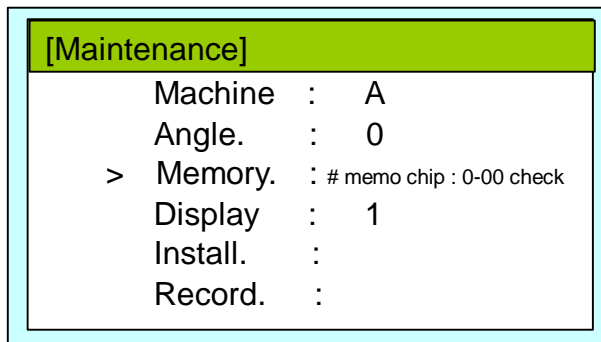

4. After display of [Chip:0-15], buzzer sounds and complete with below display.

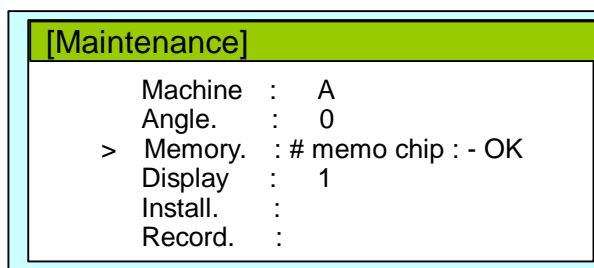

5. Below will displayed when there is defect.

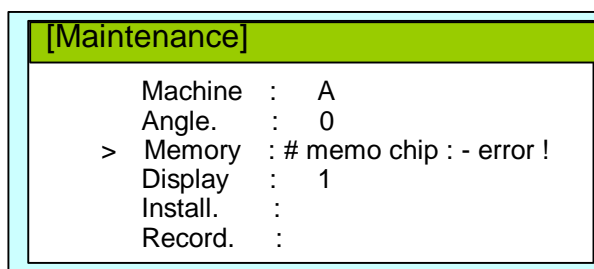

6. Return to number setting display by pressing **SET** button

7. Turn off the power once and turn on again.  
Make sure that” E-120 “is displayed.

8. Press **SET** button to turn off automatically.

9. Turn on again and make each setting, referring to [2-5 Setting of revolution],[2-6 Setting to detect needle position (12 needle)] and [ 25-1.2 Initialization of embroidery machine ] and [3-7 Date Time] at supplementary Instruction manual.

Enable to confirm past record of operation

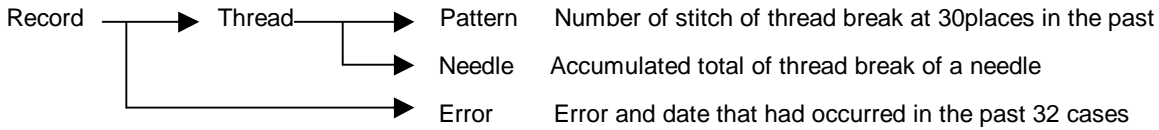

## Thread—Pattern—Number of stitch of thread break

1. Refer to “3-1 How to enter maintenance mode” and enter maintenance mode

2. Choose [ Record ] with  and press **SET** button

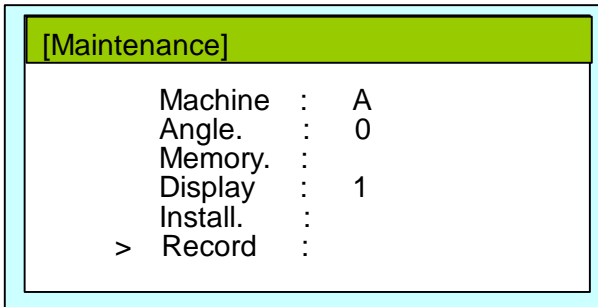

3. Choose [ Thread ] with  and press **SET** button

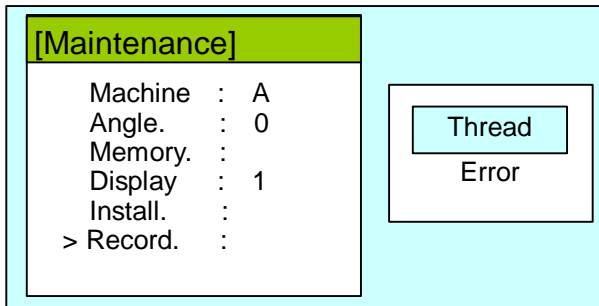

4. Choose [ Pattern ] with  and press **SET** button

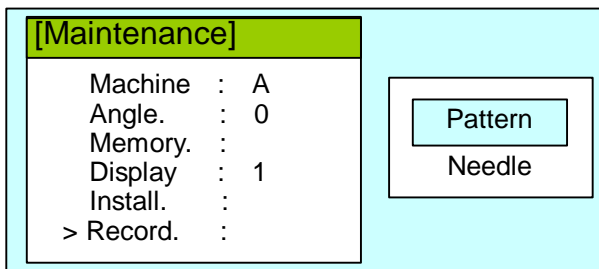

5. Press  button and select pattern you want to check, then press **SET** button

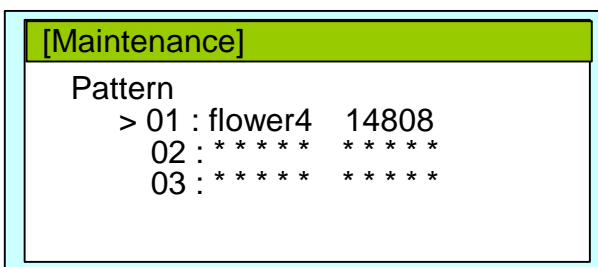

6. Press  to check the stitches of thread brake (past 30 positions).

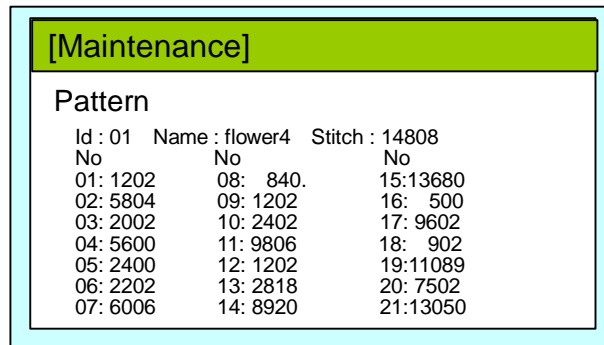

7. At the display of Step 6, press **MENU** button to open the menu to clear the numbers of stitches with thread brake.

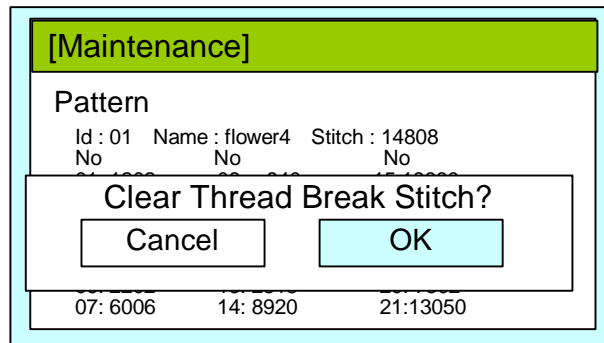

\* Select **OK** and push **SET** button to clear the numbers of stitches with thread brake and return to the display of step 6.

\* If you do not clear, select **CANCEL** and press **SET** button to return to the display of step 6.

8. Press **ESC** button to return to the display of pattern selection (Step 5).

9. Press **ESC** button again to return to the top display of maintenance mode (Step 2).



1. Refer to “3-1 How to enter maintenance mode” and enter maintenance mode

2. Choose [ Record ] with  and press **SET** button

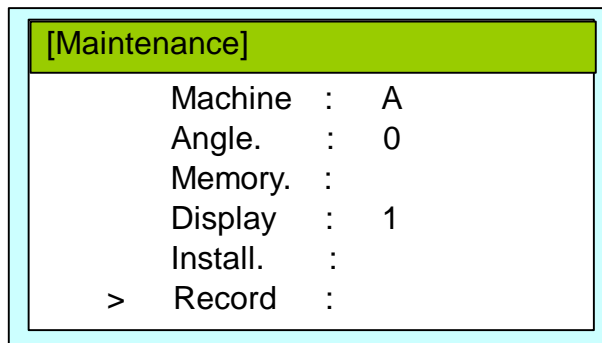

3. Choose [ Thread ] with  and press **SET** button

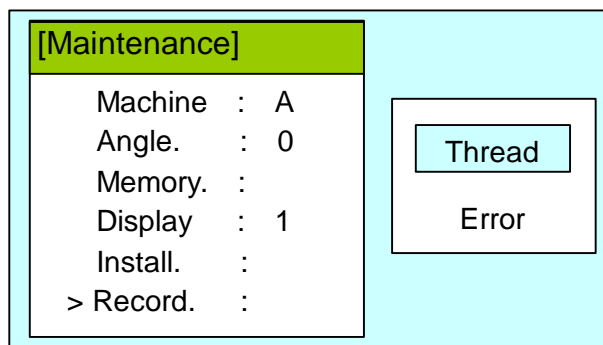

4. Choose [ Needle ] with  and press **SET** button

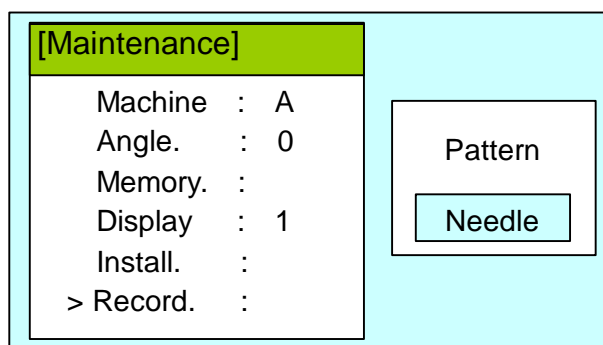

5. You can check the accumulated number of thread brake times in relation to needle.

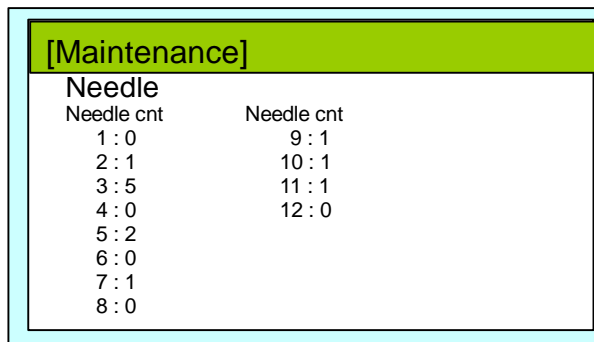

6. Press **MENU** button at the display of step 5 to open menu to clear the number of thread brake times.

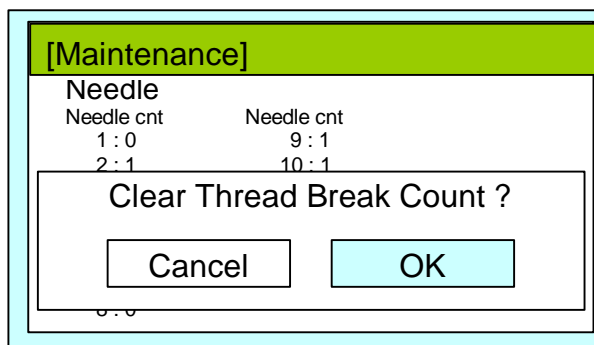

\* Select **OK** and press **SET** button to clear the accumulated number of thread brake times and return to the display of step 5.

\* If you do not clear, select **CANCEL** and press **SET** button to return to the display of step 5.

7. Press **ESC** button to return to the display of pattern selection (Step 2).

# Error occurred and the accrual date

1. Refer to "3-1 How to enter maintenance mode" and enter maintenance mode

2. Choose [ Record ] with  and press **SET** button

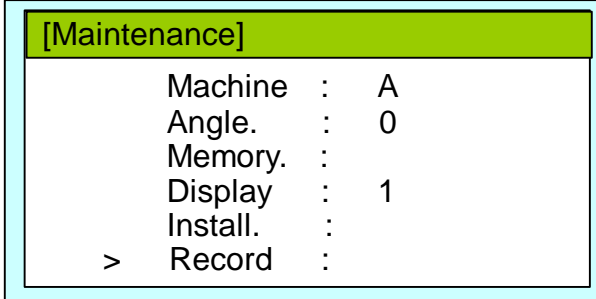

3. Choose [ Error ] with  and press **SET** button

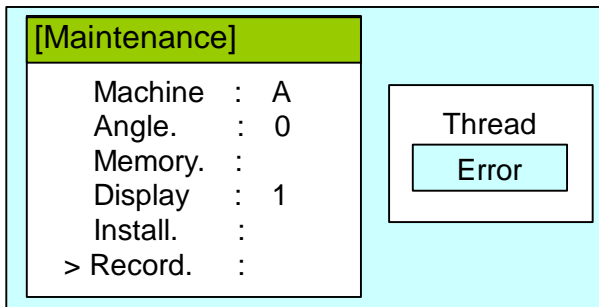

4. Enable to confirm Occurrence date and error number of last 32 cases with  button.

( Date of occurrence and error number of last 32 cases)

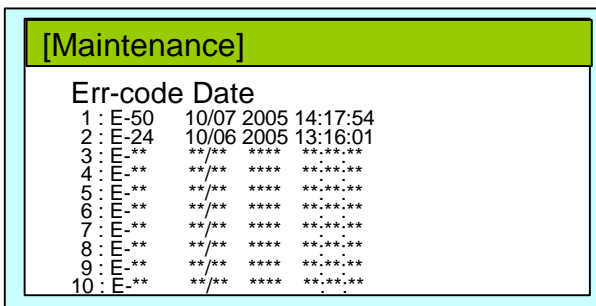

5. Selection menu of Clear Error Recode will be opened when press **MENU** button at display of procedure 4.

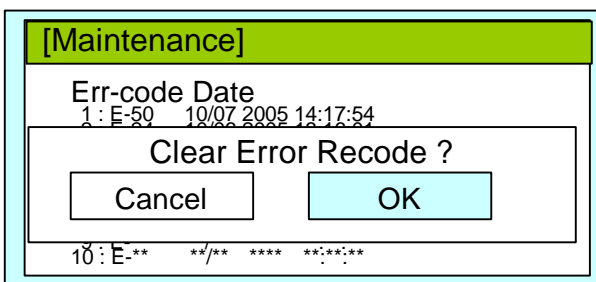

\* Enable to Clear Error Record by selecting **OK** and pressing **SET** button and return to display of Procedure 4.

\* If you prefer not to clear it, Select **CANCEL** and press **SET** button and return to display of Procedure 4.

6. Press **ESC** button to return to the display of pattern selection (Step 2).

7. Press **SET** button at the display of Step 4 to check the accumulated number of times of each error from E-000 to E-255.

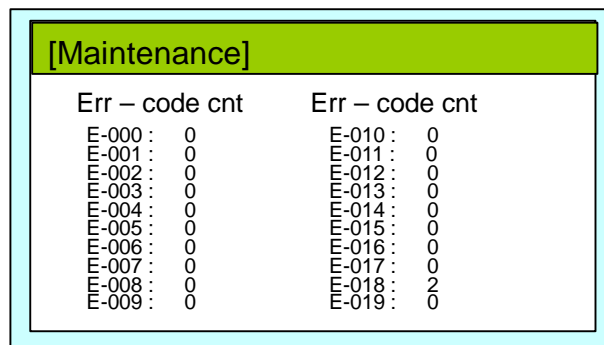

8. Press **MENU** button at the display of step 7 to open menu to clear check the accumulated number of times of each error.

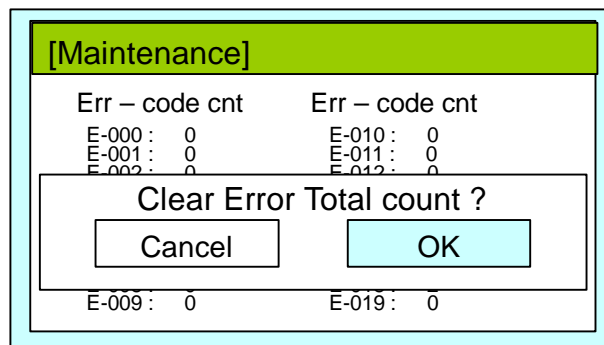

\* Select **OK** and press **SET** button to clear the accumulated number of times of each error and return to the display of step 7.

\* If you prefer not to clear it, Select **CANCEL** and press **SET** button and return to display of Procedure 7.

9. Press **ESC** button to return to the display of Step 4. Press **ESC** button again to return to the top display of maintenance mode (Step 2).

Basic machine setting will be done. All the setting will be written into built-in Flash Memory card and setting contents will not be deleted even if you proceed all memory clear

Be sure to confirm us when you modify below setting contents

Contents

Number of heads.	:1	Number of heads (in case of HCS, 1 head)
Number of needle	:12	Number of needle
Start angle of X frame movement.	:48 (20-72 degrees)	Starting angle of X frame movement
Start angle of Y frame movement.	:48 (20-72 degrees)	Starting angle of Y frame movement
Standard angle for thread cut	:212 (208-228 degrees)	Standard angle for thread cut
Longer angle for thread cut	:220 (220-240 degrees)	Longer angle for thread cut
With or with borer.	:NO	With or without borer

1. Refer to "3-1 How to enter maintenance mode" and enter maintenance mode

2. Choose [ Setup ] with  and press **SET** button

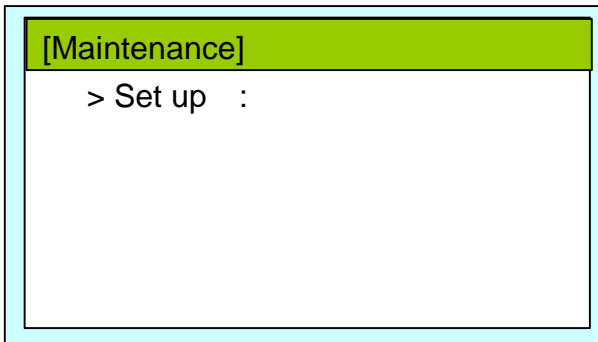

3. Press  to select desired number to be confirmed and press **SET** Button

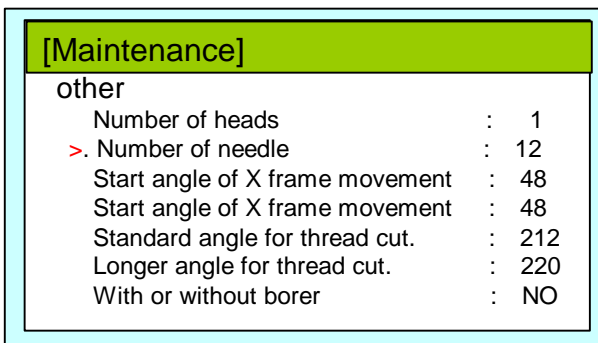

4. As the cursor moves to setting value, press  to change them to adequate value and press **SET** button.

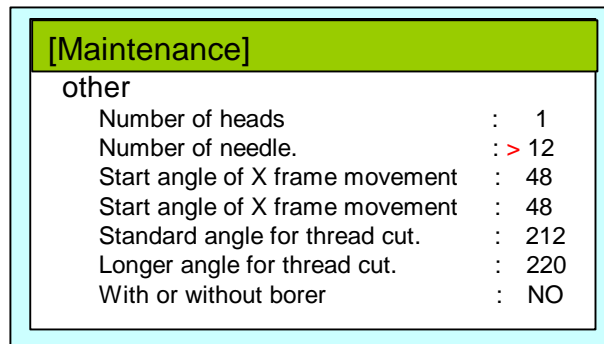

5. As confirmation message shows up, press  to select [ OK ] and press **SET** button.

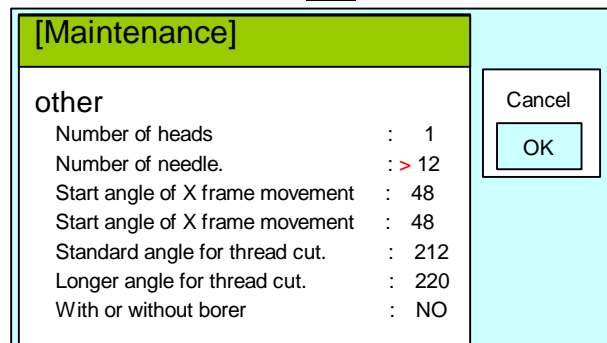

6. When this update is done, the display returns to that of Step 3.

7. Press **ESC** button to return to the previous display

## 4 Electric system diagram(Color Display)

4-1 Electrical connection diagram

4-2 List of electrical connection diagrams

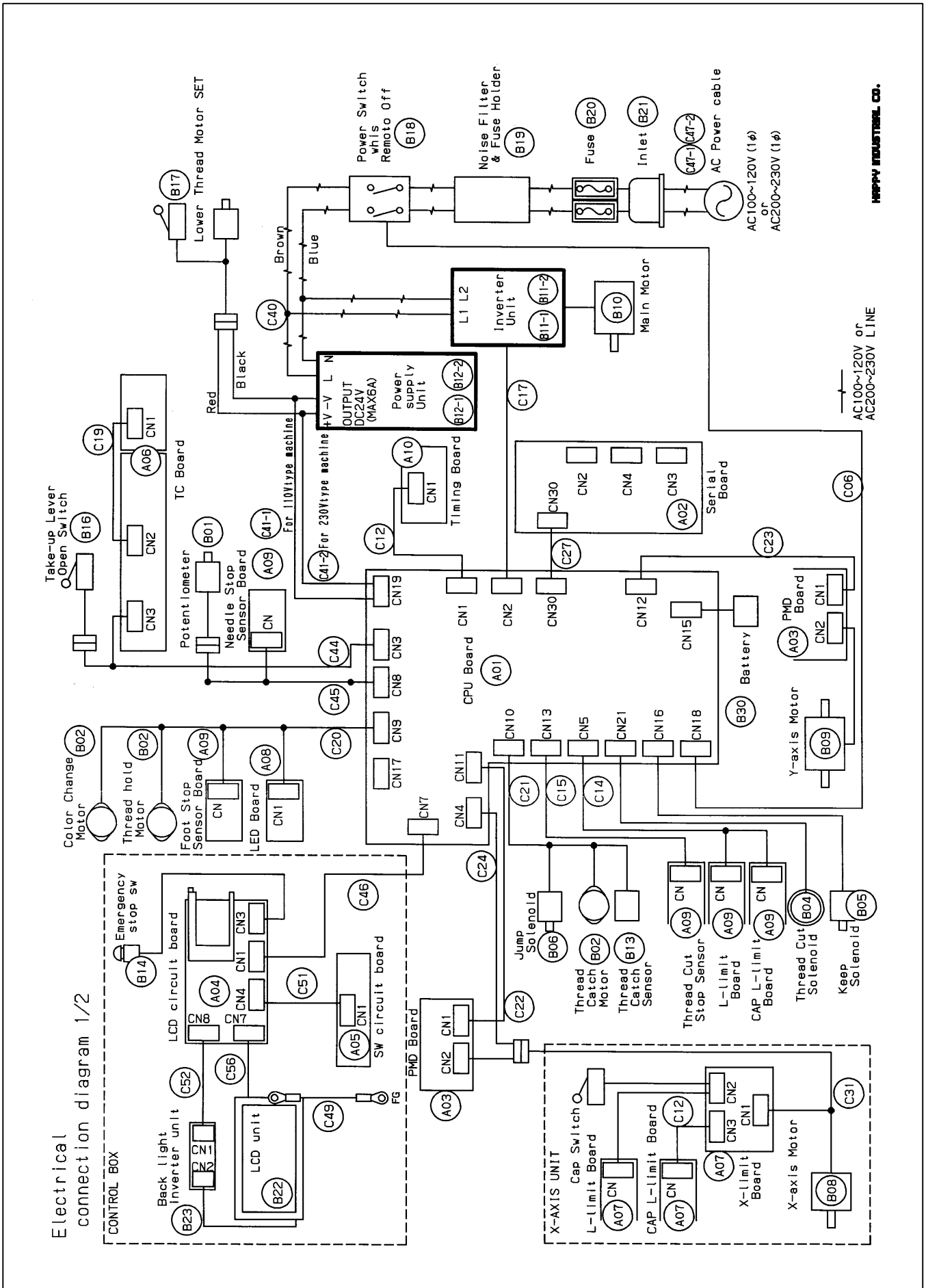

HAPPY INDUSTRIAL CO.

Electrical connection diagram 2/2

Parts Names	Parts No.	Potentiometer	ESHCS7940*	Lower Thread Motor SET	ESHCS7934*	Jump solenoid cable	ESHCS7021*
(A01) CPU Board	ESHCB8101*	(B01) Thread hold Motor	ESEPM0048* 42S1A24D5B (MATSUSIITA)	(B17) Power Switch Remoto Off	ESEFS0089* AJBR2014BBC (MATSUSIITA)	(C21) XPulse motor cable	ESHCS7022*
(A02) Serial Board	ESHCB8107*	(B02) Color Change Motor	ESEPM0048* 42S1A24D5B (MATSUSIITA)	(B19) Noise Filter & Fuse Holder	ESHCS7946*	(C23) YPulse motor cable	ESHCS7023*
(A03) PMD Board	ESHCB8104*	(B02) Thread Catch Motor	ESEPM0048* 42S1A24D5B (MATSUSIITA)	(B20) Fuse	ESEPF0036* 3SB6A (Bel) 250V 6A	(C24) XLimit switch relay cable	ESHCS7024*
(A04) LCD&ATACF Board	ESHCD8102*	(B04) Thread Cut Solenoid	ESHCS7910*	(B21) Inlet	ESHCS7944*	(C27) Serial relay cable	ESHCS7027*
(A05) Switch Board	ESHCD8103*	(B05) Keep Solenoid	ESHCS7905*	(B22) LCD unit	ESEPZ0079* KCG089H1AA-G00 (KYOSERA)	(C31) XPulse motor relay cable	ESHCS7031*
(A06) TC Board	ESHCB8105*	(B06) Jump Solenoid	ESHCS0850*	(B23) Back light Inverter unit	ESEPZ0080* CXA-L0605-VJL (TDK)	(C40) Power relay cable	ESHCS7040*
(A07) X-limit Board	ESHCB8110*	(B08) X-axis Motor	ESHCS7920*	(B30) Battery	ESEPZ0054*	(C41-1) Power cable with the fuse (24V) or (C41-2) Power cable (24V)	ESHCS7942* for 110V type machine ESHCS7041* for 230V type machine
(A07) L-limit Board	↑	(B09) Y-axis Motor	ESHCS7921*				ESEPE0005*
(A07) CAP L-limit Board	↑	(B10) Main Motor	ESHCS7931* OR ESHCS7930* 3φ 90W	(C06) PD cable	ESHCS7006*	(C47-1) AC Power cable (110V) or (C47-2) AC Power cable (220V)	ESHCS7048*
(A08) LED Board	ESHCB8112*	(B11-1) Input 110V type Inverter Unit	ESEPM0053* FR-S510W-0.2K-R-* or FR-S510WE-0.2K-*	(C12) XL cable	ESHCS7012*	(C45) TC cable	ESHCD7049*
(A09) Foot Stop Sensor Board	ESHCB8111*	(B11-2) Input 220V type Inverter Unit	ESEPM0049* VFNC1S-1004P (TOSHIBA)	(C14) YF cable	ESHCS7014*		ESHCS7044*
(A09) Needle Stop Sensor Board	↑	(B12-1) Input 110V type Power supply	ESEPM0050* VFNC1-2004P (TOSHIBA)	(C15) ORG cable	ESHCS7015*	(C46) DISP (LCD) cable	ESHCS7048*
(A09) Thread Cut Stop Sensor Board	↑	(B12-2) Input 220V type Power supply	ESHCS7925* DC24V MAX6A OUTPUT	(C16) Timing cable	ESHCS7016*	(C49) LCD Ground cable	ESHCD7049*
(A09) L-limit Board	↑	(B13) Thread Catch Sensor	ESHCS7926* DC24V MAX6A OUTPUT	(C17) INVERTER cable	ESHCS7017*	(C51) SW cable	ESHCD7051*
(A09) CAP L-limit Board	↑	(B14) Emergency stop SW	ESEPP0052* GP1A73A (SHARP)	(C45) Needle bar change cable	ESHCS7045*	(C52) BL-Inverter cable	ESHCD7052*
(A10) Timing Board	ESHCB8109*	(B16) Take-up Lever Open Switch	ESHCD7900*	(C19) TC connecting cable	ESHCS7019*	(C56) LCD-S (φ. 9 inch) cable	ESHCD7056*

\*mark is a revision number

Product varies in a power supply to use

KIPPY INDUSTRIAL CO.